

THIS DOCUMENT IS FOR REFERENCE ONLY. USERS MUST ASSURE THEY ARE USING THE CORRECT REVISION

REVISIONS				
REV. SYM.	E.C.O. NUMBER	DESCRIPTION	BY DATE	APP'D DATE
5		MEASURING INSTRUCTIONS ADDED	M.SCRUGGS DE 7/20/95	DE 8-17-95
6		REMOVED REF'S TO OLD DESIGN	K. KOONS 6.30.15	

**UNCONTROLLED DOCUMENT
WILL NOT BE UPDATED**
DIMENSIONS IN INCHES - UNLESS OTHERWISE SPECIFIED

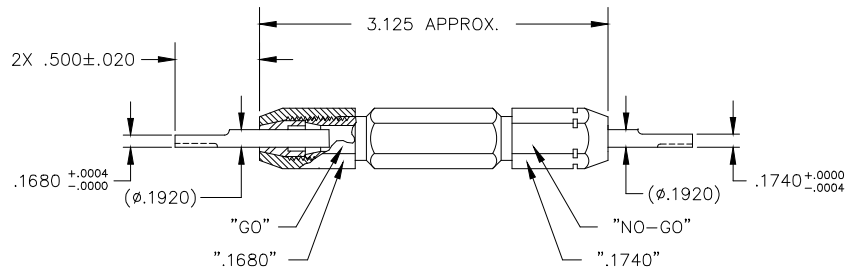

FIGURE 1

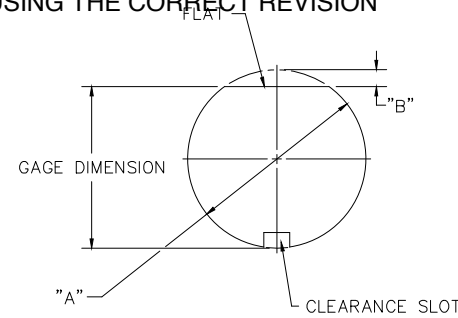

FIGURE 2

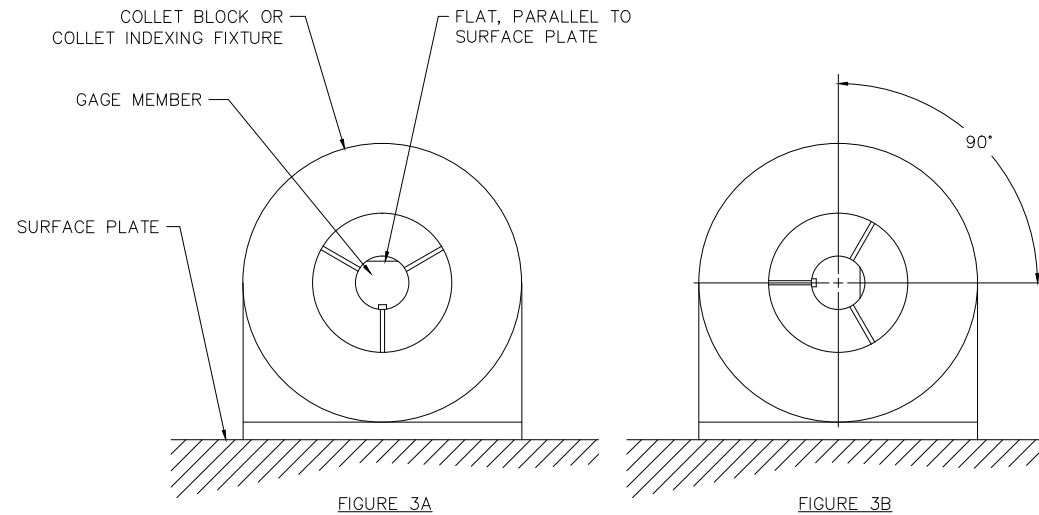



FIGURE 3A

FIGURE 3B

FIGURE 3

GAGE MEMBER MEASUREMENT

- DO NOT ATTEMPT TO MEASURE THE GAGING DIMENSION FROM THE FLAT TO THE CORNERS OF THE CLEARANCE SLOT. THE FLAT DIMENSION IS RELATIVE TO THE DIAMETER.
- REMOVE GAGE MEMBER FROM GAGE BY LOOSENING THE CAP.
- MEASURE THE DIAMETER "A" (FIGURE 2) USING A MICROMETER.
- PLACE THE GAGE MEMBER IN A SUITABLE COLLET BLOCK OR COLLET INDEXING FIXTURE (FIGURE 3A), INDICATING THE FLAT TO INSURE THAT IT IS PARALLEL WITH THE SURFACE PLATE.
- ROTATE THE COLLET 90° (FIGURE 3B) AND ZERO THE HEIGHT GAGE TO THE TOP OF DIAMETER "A".
- ROTATE THE COLLET TO IT'S ORIGINAL POSITION (FIGURE 3A). MEASURE DOWN TO THE FLAT TO DETERMINE DIMENSION "B" (FIGURE 2).
- THE FOLLOWING FORMULA DETERMINES THE THE GAGE DIMENSION:
 $GAGE\ DIMENSION = A - B$
- IF THE GAGE MEMBER IS WITHIN THE LIMITS SHOWN IN FIGURE 1, IT IS SERVICEABLE AND MAY BE RE-INSTALLED IN THE GAGE.
- REPEAT WITH THE OTHER GAGE MEMBER.

RESTRICTED & CONFIDENTIAL		MATERIAL		ITEM	PART NO.	QTY.	DESCRIPTION/REMARKS			
CONFIDENTIAL PROPERTY OF DANIELS MANUFACTURING CORP. NOT TO BE DISCLOSED TO OTHERS, REPRODUCED OR USED FOR ANY OTHER PURPOSE, EXCEPT AS AUTHORIZED IN WRITING BY DANIELS MANUFACTURING. MUST BE RETURNED TO DANIELS MANUFACTURING CORP. ON COMPLETION OF ORDER OR OTHER PURPOSE FOR WHICH LENT.		HEAT TREAT		DRN:	DATE	 DANIELS MANUFACTURING CORP. ORLANDO, FLORIDA GAGE 11851				
		FINISH		CHK'D:	DATE					
		DO NOT SCALE DRAWING				APP'D:	DATE	TITLE		
				D.DEAPIVA	8-95	C668 GO/NO-GO GAGE				
				APP'D:	DATE	ENVELOPE AND INSPECTION DRAWING				
				NOTE:		WHERE USED:				
				THIS DRAWING IS AN OUTLINE DRAWING OF THE RESPECTIVE DMC PART NUMBER INDICATED. ACTUAL DMC PART NUMBER IS DRAWING NUMBER WITHOUT THE "-ENV" SUFFIX.		SIZE	SCALE	CAD P/N	SHEET	OF
						C	NTS	G668-ENV	1	1
						POSTING	P/N	G668	REV.	6