

USERS MUST ASSURE THEY ARE USING THE CORRECT REVISION.

REVISIONS						
REV	ECO NO.	DESCRIPTION	BY	DATE	APP'D BY	DATE
1		ORIGINAL RELEASE	K. KOONS	11/16/2015		

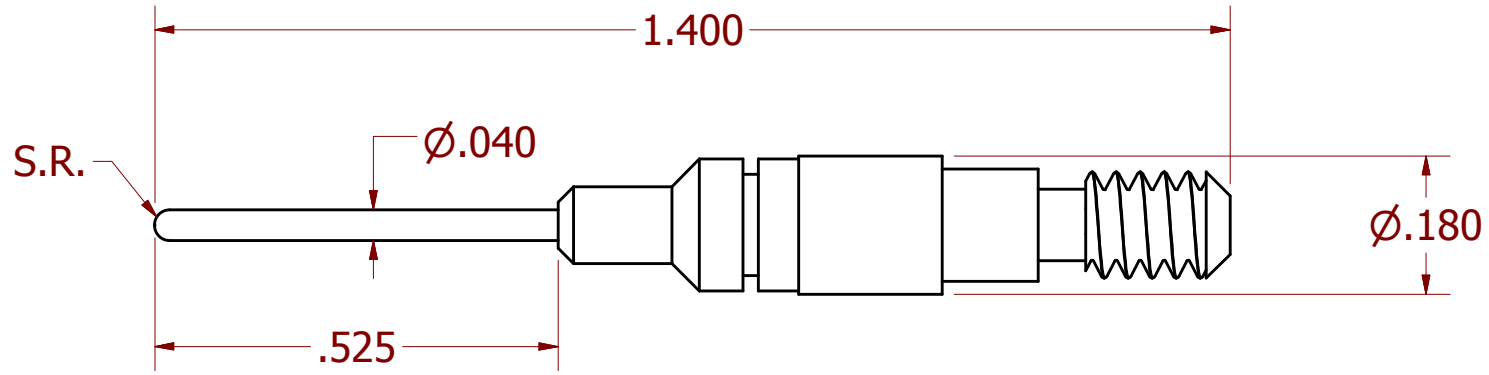

**UNCONTROLLED DOCUMENT
WILL NOT BE UPDATED**

DIMENSIONS IN INCHES - UNLESS OTHERWISE SPECIFIED

NOTES:

MATERIAL	ITEM	PART NO.	QTY.	DESCRIPTION / REMARKS
NA	DRN. DJR CHK'D. KR	DATE 3/8/1985 DATE 3/11/1985		 DANIELS MANUFACTURING CORP. ORLANDO, FLORIDA CAGE 11851
HEAT TREAT	NOTE: THIS DRAWING IS AN OUTLINE DRAWING OF THE RESPECTIVE DMC PART NUMBER INDICATED. ACTUAL DMC PART NUMBER IS CAD PART NUMBER WITHOUT THE "-ENV" SUFFIX		TITLE TIP, SOCKET TESTER (HT210) ENVELOPE DRAWING	
FINISH			WHERE USED: SIZE A SCALE CAD P/N 67-020-01-ENV SHEET 1 OF 1 DWG. NO. 67-020-01 REV. 1	

RESTRICTED & CONFIDENTIAL
 CONFIDENTIAL PROPERTY OF DANIELS MANUFACTURING CORP. NOT TO BE DISCLOSED TO OTHERS. REPRODUCTION OR USED FOR ANY OTHER PURPOSE EXCEPT AS AUTHORIZED IN WRITING BY DANIELS MANUFACTURING. MUST BE RETURNED TO DANIELS MANUFACTURING CORP. ON COMPLETION OF ORDER OR PURPOSES FOR WHICH LENT.

CREATED FROM AN INVENTOR MODEL.
 CHANGES MUST BE REFLECTED IN THE 3D PART

DO NOT SCALE DRAWING